



# SPRING-LOADED WHEELED AMPERAGE CONTROL

- Returns to off automatically
- Insures electrode not "hot" when not in use
- Great for tack welding, short or long welds, and "bumping" technique
- Spring included with installation instructions
- Can be positioned closer to torch head for optimum torch control

Remote amperage controls provide welding machine contactor on-off, activate gas and/or water solenoids, and provide full range current output control. Handle style includes Velcro® straps where one size fits all handle diameters and retrofits easily on all makes of TIG torches.

*Spring-loaded wheel (optional)*

*Fully enclosed housing, protects potentiometer*

*Metal shielded cable protects against high frequency*

*Velcro® straps secure control to the handle*



# SPRING-LOADED WHEELED AMPERAGE CONTROL REPLACEMENT PARTS

**OTHER AMPERAGE CONTROLS OFFERED BY CK**



**ROTARY AMPERAGE CONTROL**

Replace foot pedal amperage controls with fingertip operated amperage controls, available as a complete handle assembly.



**LINEAR AMPERAGE CONTROL**

Linear slide actuator for complete on/off and full amperage control. Protected against high frequency.

MACHINE MAKE POTENTIOMETER RATING	AMPERAGE CONTROL TYPE	PLUG CONFIGURATION & PIN COUNT	CONTROL CABLE LENGTH	VELCRO™ STRAPS
				ONE SIZE FITS ALL
LINCOLN ELECTRIC 10K Ohm	Wheel	5 Pin Plug	15 ft. (4.6 m)	<b>WACCV-10-1-L5</b>
			28 ft. (8.5 m)	<b>WACCV-10-2-L5</b>
			53 ft. (16.2 m)	<b>WACCV-10-3-L5</b>
		6 Pin Plug	15 ft. (4.6 m)	<b>WACCV-10-1-L6</b>
			28 ft. (8.5 m)	<b>WACCV-10-2-L6</b>
			53 ft. (16.2 m)	<b>WACCV-10-3-L6</b>
MILLER ELECTRIC 1K Ohm	Wheel	14 Pin Plug	15 ft. (4.6 m)	<b>WACCV-1-1-M14</b>
			28 ft. (8.5 m)	<b>WACCV-1-2-M14</b>
			53 ft. (16.2 m)	<b>WACCV-1-3-M14</b>
		5 Pin Plug	15 ft. (4.6 m)	<b>WACCV-1-1-M5</b>
			28 ft. (8.5 m)	<b>WACCV-1-2-M5</b>
			53 ft. (16.2 m)	<b>WACCV-1-3-M5</b>
THERMAL DYNAMICS 5K Ohm	Wheel	14 Pin Plug	15 ft. (4.6 m)	<b>WACCV-5-1-TD14</b>
			28 ft. (8.5 m)	<b>WACCV-5-2-TD14</b>
			53 ft. (16.2 m)	<b>WACCV-5-3-TD14</b>
		8 Pin Plug	15 ft. (4.6 m)	<b>WACCV-5-1-TD8</b>
			28 ft. (8.5 m)	<b>WACCV-5-2-TD8</b>
			53 ft. (16.2 m)	<b>WACCV-5-3-TD8</b>

## EXPLODED VIEW

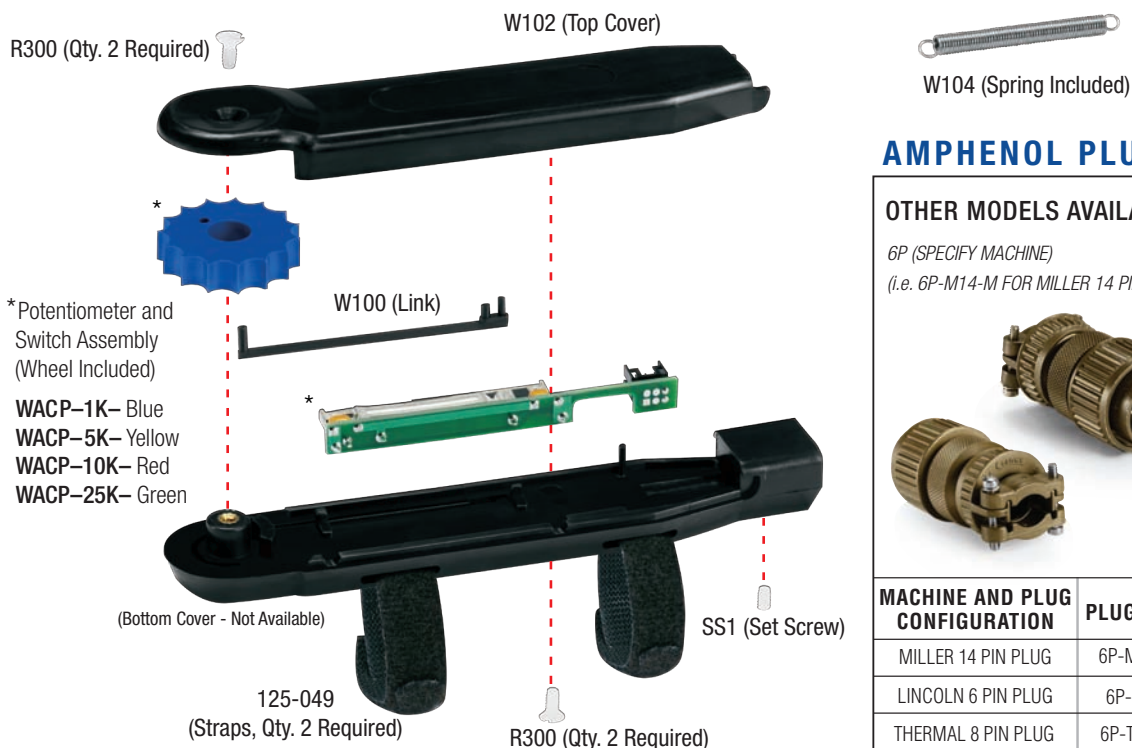

## AMPHENOL PLUGS

### OTHER MODELS AVAILABLE

6P (SPECIFY MACHINE)  
(i.e. 6P-M14-M FOR MILLER 14 PIN PLUG)



MACHINE AND PLUG CONFIGURATION	PLUG TYPE
MILLER 14 PIN PLUG	6P-M14-M
LINCOLN 6 PIN PLUG	6P-L6-M
THERMAL 8 PIN PLUG	6P-TD8-M

CK Worldwide Inc., PO Box 1636, Auburn, WA 98071 USA  
Phone: 1.800.426.0877 Fax: 1.800.327.5038

[www.CKWORLDWIDE.com](http://www.CKWORLDWIDE.com)  
FORM420